

# JCB-G8000PE

Original Instructions

## Contents

Page Heading	
Introduction	3
General Warnings & Disposal	4-5
<b>Safety Information</b>	<b>6-11</b>
General Safety & Understand Your Machine	6
Personal Safety	7
Inspect Your Machine	8
Work Area & Machine Specific Safety	9
Fuel Safety & Spilled Fuel	10
Fuelling/De-Fuelling & Storage	11
<b>Features</b>	<b>12-13</b>
Features	12
Feature Descriptions	13
<b>Assembly</b>	<b>14</b>
<b>Pre-Operation Checks</b>	<b>15-17</b>
Oil Level & Air Filter Inspection	15
Check Fuel Level & Recommended Fuel	16
Electrical Unloading	17
Machine Grounding	17
Battery Connection	17
<b>Operation</b>	<b>18-22</b>
Starting	18-19
Stopping	20
Connecting Appliances	21
Power Management	22
<b>Maintenance</b>	<b>23-27</b>
Importance of Maintenance & Maintenance Safety	23
Maintenance Schedule	24
Oil Servicing	25
Spark Plug	26
Sediment Filter	27
Cleaning Air Filter	27
<b>Troubleshooting</b>	<b>28</b>
<b>Wiring Diagram</b>	<b>29</b>
<b>Specification</b>	<b>30</b>
<b>Warranty, Manual Updates, Returns, Reviews &amp; Spare Parts</b>	<b>31</b>
<b>Contact Us</b>	<b>32</b>
<b>Recycling and Disposal &amp; Environmental Protection</b>	<b>33</b>
<b>CE Declaration of Conformity</b>	<b>34</b>
<b>UKCA Declaration of Conformity</b>	<b>35</b>

## Introduction

We work very hard to give all of our customers the best possible service. If you have any problems, before leaving negative feedback, please contact us to give us a chance to resolve the issue. We would be delighted if you left us positive feedback! Thank you for purchasing this product.

## Important!



### **WARNING: READ THE INSTRUCTION BOOKLET THOROUGHLY BEFORE USING THE MACHINE.**

Keep for future reference and pass it on if the machine is loaned or sold to another user.

This manual has been produced by Genpower Ltd, and should be kept with the product. Please read and understand these instructions before you use your product. Failure to do this may result in personal injury or damage to the product.

The safety precautions and warnings are to ensure your safety and protect you from harm or damage to the product.

The information contained in this manual was accurate at the time of production, however Genpower Ltd & JCB may make modifications to the product without notification.



# GENERAL WARNINGS & DISPOSAL

You will find the following Symbols and Icons on the stickers of your machine. Please take note when you see them as they mean the following:



To reduce the risk of injury, the user must read the instruction manual



This symbol is used throughout this manual to warn the user about potential risks. Please read & understand these sections before using the device.



Personal Protective Equipment (P.P.E.) to be worn during operation such as:

- Gloves and Hand Protection
- Safety Glasses and Eye Protection
- Ear Defenders for Sound Protection
- Protective Head gear



Waste Electrical and Electronic Equipment (WEEE) : When disposing the machine you must conform to WEEE regulations.



Exhaust Gas Warning : Exhaust Gas from this machine is poisonous, NEVER operate in an unventilated area



Hot Surface Warning : During the operation of this machine, it becomes dangerously hot. Allow to cool before moving



Fire Risk Warning : Due to using flammable liquids, risk of fire is always present. NEVER refuel during operation.



Proximity Warning : Ensure during operation a 4ft boundary is observed.



Sound Warning : This machine exerts 97dB of noise during operation. Ensure this is considered whilst operating.



Detonation Warning : Prior to refuelling always turn off the machine. After refuelling check for spilt fuel. NEVER operate near open flames.

# GENERAL WARNINGS & DISPOSAL



Water Exposure Warning : Never allow the machines to be exposed to rain or wet conditions.



Electrocution Warning : This machine is a potential source of electrical shock. Never expose to moisture, rain or snow. Do not operate with wet hands or feet.



Grounding Warning : Failure to properly ground this machine can result in electrocution.



Ground Location : This shows suitable areas where the machine can be connected to ground.

Carbon Monoxide Warning:



**BREATHING IN CARBON MONOXIDE FUMES CAN CAUSE DEATH!**  
 Using a generator indoors in an unventilated area **CAN KILL YOU IN MINUTES!**  
 The exhaust fumes from machines contain Carbon Monoxide. This is a poisonous gas that you can't see or smell.

- NEVER use inside a building with poor ventilation even IF the doors and windows are open.
- NEVER use inside a confined space such as but not limited to a house, garage, large vehicle, boat or tent.
- Never operate the machines near other machines which use flammable liquids as a fuel source.
- Only use the machine outside far away from open windows, doors and vents.



# Safety Information

## General Safety

No list of safety guidelines can be complete. Every environment is different. Always consider safety first, as it applies to your individual working conditions. Use this and other machinery with caution and respect. Failure to do so could result in serious injury, damage to equipment, or poor work results.

 This symbol is used throughout this manual to warn the user about potential risks. Please read & understand these sections before using the device.

## Understand Your Machine

- **WARNING!** You must read these instructions carefully before operating the machine. Make sure that you are familiar with the controls and properly operate the machine. You must learn how to stop the machine quickly. If you do not follow the warnings and instructions, it may result in fire and/or serious injury. Make sure to save all warnings and instructions for future reference.
- Read this manual and labels affixed to the machine to understand its limitations and potential hazards.
- Be thoroughly familiar with the controls and their proper operation. Know how to stop the machine and disengage the controls quickly.
- If the unit is to be used by someone other than original purchaser, or is to be loaned, rented, or sold, always provide this manual and any needed safety training before operation. The user can prevent and is responsible for accidents or injuries that may occur to themselves, to other people, or to property.
- Do not force the machine beyond its limits. Use the correct machine for your application.
- Know how to stop the machine quickly in case of emergency. Understand the use of all controls.
- ALL MAINTENANCE other than that listed in this manual, should be carried out by professionally trained and certified personnel.
- When using this machine for the first time and before actual work, you **MUST** learn how to handle the machine from an experienced or skilled person.

# Safety Information

## Personal Safety

- **WARNING!** Never allow children or people unfamiliar with these instructions to use the product. Local regulations can restrict the minimum age of the operator.
- Keep children, pets, and other people not using the unit away from the work area (at least 15m). Be alert and shut off the unit if anyone enters work area. Keep children under the watchful care of a responsible adult.
- Stay alert, watch what you are doing and use common sense when operating the machine. Never operate the machine when unwell or tired, or if you have taken alcohol, medicine, drugs or any substances which may slow your reflexes and compromise judgment. A moment of inattention while operating the machine may result in serious personal injury.
- Appropriate Personal Protective Equipment (PPE), **MUST** be worn at all times when operating or repairing the machine. Always wear anti-slip and resistant work footwear and long trousers while using the machine. Do not use the machine when barefoot, wearing sandals or similar lightweight footwear. Do not wear chains, bracelets or clothing that is loose fitting or hanging ties or cords. Tie long hair back. Always wear protective earplugs. Loose clothes, jewellery, or long hair can be caught in moving parts. Protect eyes, face, and head from objects that may be thrown from the unit. Always wear safety goggles or safety glasses with side shields when operating.
- Always keep hands and feet away from all moving parts during operation. Moving parts can cut or crush body parts. Always keep hands and feet away from all pinch points.
- Do not touch parts that might be hot from operation. Allow parts to cool before attempting to maintain, adjust, or service.
- Never place any part of your body where it would be in danger if movement should occur during assembly, installation, and operation, maintenance, repairing or moving.
- Start the machine carefully according to instructions.
- Keep in mind that the operator or user is responsible for accidents, hazards or unexpected events involving the machine that occur to other people or their property. It is the responsibility of the user to assess the potential risk of the area where work is being carried out. The operator or user must take all necessary precautions to ensure their own safety and that of others, especially on slopes or rough, slippery and unstable ground.



# Safety Information

## Inspect Your Machine

- Check your machine before starting it. Keep guards in place and in working order. Make sure all nuts, bolts, etc., are securely tightened.
- You must check the general condition of the machine before use.
- Never operate the machine when it is in need of repair or is in poor mechanical condition. Replace damaged, missing, or failed parts before using it. Check for fuel leaks. Keep the machine in safe working condition.
- Do not use the machine if the engine's switch does not turn off the engine when running. Any petrol powered machine that can't be controlled with the engine switch is dangerous and must be replaced.
- Regularly check to see that keys and adjusting wrenches are removed from the machine area before starting it. A wrench or a key that is left attached to a rotating part of the machine may result in personal injury.
- If the machine should start to vibrate abnormally, stop the engine and check immediately for the cause. Vibration is generally a warning sign of trouble.
- Avoid accidental starting. Be sure the engine's switch is off before transporting the machine or performing any maintenance or service on the unit. Transporting or performing maintenance or service on a machine with its switch on invites accidents.
- Do not tamper with or disable safety systems.
- Only use manufacturer-recommended attachments.
- Before using, always visually inspect to see that the tools are not worn out or damaged. Replace worn out or damaged elements and bolts in set to preserve balance.
- Keep the machine in good operating condition. Operating the machine in poor or questionable condition could result in serious injury.
- Be sure all safety devices are in working order and warning labels are in place. These items are installed for your safety.



# Safety Information

## Work Area

- Make sure you thoroughly inspect the entire work area. You must only work in daylight or with good artificial light in good visibility conditions. Do not work at night, at times of heavy fog, or at any other times when your field of vision might be limited and it would be difficult to gain a clear view of the area.
- Keep people, children and animals away from the working area.
- Operate on flat, level ground.
- Never leave the machine in a place with unstable ground which could give way.
- You must be careful near ravines, ditches or embankments.
- Exercise extreme caution when operating on or crossing gravel drives, walks, or roads. Stay alert for hidden hazards or traffic.
- Pay the utmost attention when working on frozen ground as the machine may tend to slide.
- Do not work in the rain, when there is a thunderstorm or lightning risk, at times of strong or gale force winds, or at any other times when the weather conditions might make it unsafe to use this product. If there is bad weather conditions, do not use the machine.

## Machine Specific Safety

- Never Use the machine in wet conditions
- This machine is powered by flammable fuel which can result in a fire or explosion, causing serious injury.



## Safety Information

### Fuel Safety



**CAUTION! ALL FUELS ARE HIGHLY FLAMMABLE & PETROL VAPOUR IS EXPLOSIVE. TAKE EXTREME CARE WHEN HANDLING FUEL. KEEP FUEL OUT OF REACH OF CHILDREN.**

- NEVER smoke when handling fuel.
- ALWAYS avoid inhaling fumes.
- ALWAYS carry fuel in the correct and clearly marked container.
- ALWAYS wear correct, suitable and fit for purpose Personal Protective Equipment (PPE), suggested items are but not limited to safety gloves and overalls.
- To avoid sparking or arcing, keep grounded conductive objects such as tools away from exposed, live electrical parts and connections. These events could ignite fumes or vapours.
- Do not operate the machine with known leaks in the fuel system.
- Fire hazard - keep fuel away from all sources of ignition for example heaters, lamps, sparks from grinding or welding.
- DO NOT carry out hot work on tanks that have contained fuel.
- ALWAYS keep the work area tidy.
- ALWAYS dispose of waste fuels correctly.
- Serious personal injury can occur when petrol is spilled on yourself or your clothes. Rinse your skin and change your clothes immediately.

### Spilled Fuel

- If you have spilled fuel, make sure you do not attempt to ignite the engine but move the machine away from the area of spilled fuel and avoid creating any source of ignition until the fuel has evaporated and fuel vapours have dissipated.
- When fuel is spilled on yourself or your clothes, wash your skin and change clothes immediately.
- ALWAYS clean up spills promptly using absorbent granules and a lidded bin.

# Safety Information

## Fuelling / De-Fuelling

- ALWAYS fuel and de-fuel in a well ventilated area outside of buildings. Use a funnel to add fuel, only outdoors. Do not smoke during this and each time fuel is handled.
- Add fuel before igniting the engine, never remove the fuel tank cap or add fuel whilst the engine is running or when it is hot.
- When de-fuelling ALWAYS use a proper fuel retriever.
- Never overfill the fuel tank. Engine heat can cause fuel to expand, never fill the tank to more than 1/2" below the bottom of the filler neck. This will provide space for fuel expansion.
- When refilling or draining the fuel tank, use an approved fuel storage container while in a clean, well-ventilated outdoor area. While adding fuel or operating the unit, do not smoke, and stay away from sparks, open flames, or other sources of ignition near the area of operation.
- Always stop the engine and allow it to cool before filling the fuel tank. Never remove the cap of the fuel tank or add fuel while the engine is running or when the engine is hot.
- Loosen the fuel tank cap slowly to relieve any pressure in the tank.
- ALWAYS keep the handles dry, clean and free of oil and fuel.
- After fueling, ensure to tighten the cap securely.
- Never use the lock-function when filling with fuel.

## Storage

- Store fuel in containers specifically designed and approved for fuel storage.
- Store fuel in a cool, well-ventilated area, safely away from sparks, open flames, or other sources of ignition.
- Never store fuel or a machine with fuel in the tank inside a building where fumes may reach a spark, open flame, or any other source of ignition (such as a water heater, furnace, or clothes dryer). Allow the engine to cool before storing in any enclosure.
- Replace all fuel tank and container caps securely and wipe up spilled fuel. Never operate the unit without the fuel cap securely in place.



# Features

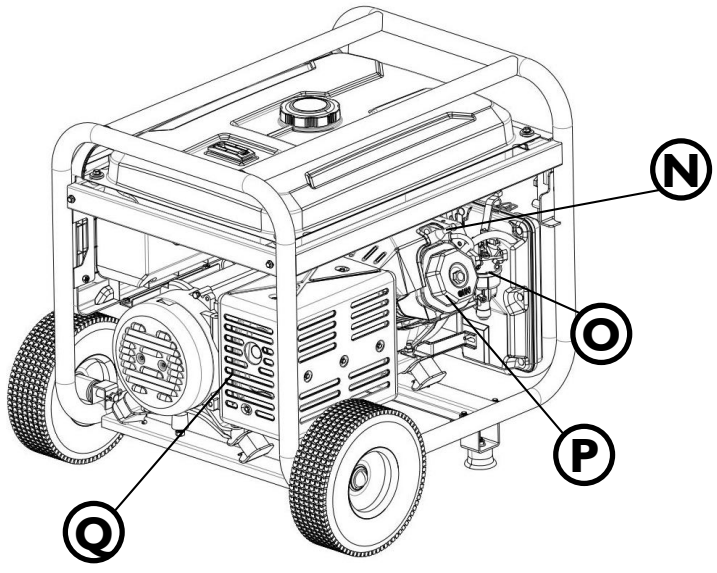
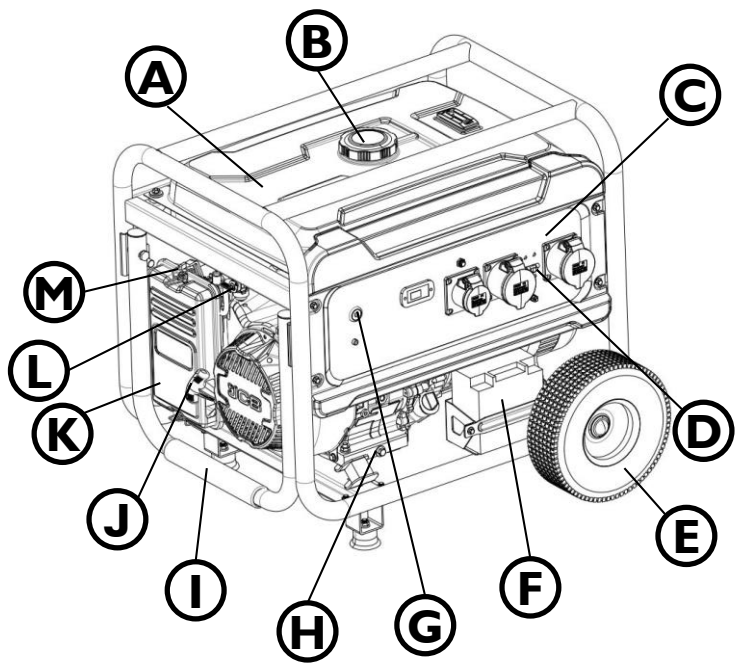

## Feature Descriptions

**A** – Fuel Tank

**B** – Fuel Tank Cap

**C** – Control Panel (May appear different on your machine)

**D** – AC Outputs – These provide 115V & 230V outputs

**E** – Machines Wheels – Used to transport the machine.

**F** – AC Circuit Breaker – This protects electrical circuits from overcurrent, overload and short circuiting.

**G** – Engine Switch & Key Start – Turns the machine On and Off

**H** – Oil Drain Plug – Used to drain oil for routine maintenance.

**I** – Movement Handle – Used to transport the machine.

**J** – Recoil Starter – Used to turn the engine and start the machine.

**K** – Air Filter – Cleans the air for ideal performance.

**L** – Fuel Valve – Changes the flow of fuel to the carburettor

**M** – Choke Valve – Adjusts the amount of air flowing through the carburettor

**N** – Spark Plug – Provides spark for combustion.

**O** – Carburettor – Mixes Fuel air for combustion.

**P** – Cylinder Head

**Q** – Exhaust – Muffles the noise from the exhaust.



# Assembly

## Wheels

- > Insert the Mini Axle through the washer and then through a wheel.
- > Place this through the location hole on the generator frame.
- > Secure into place by inserting the R-clip through the hole in the Mini Axle
- > Repeat this on both sides.

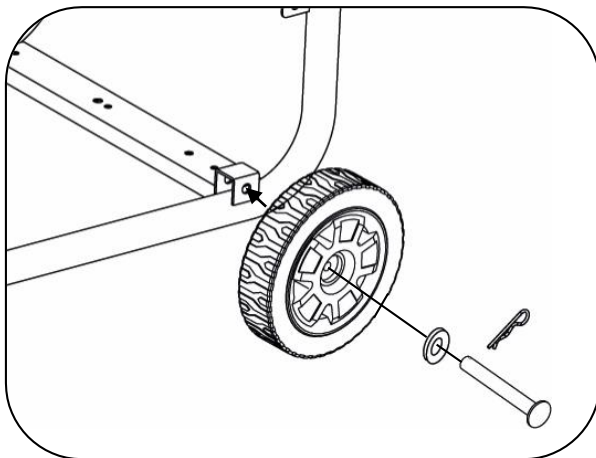

## Handle

- > Place the bar ends in either end of the machine handle.
- > Line up the holes in the Handle with the corresponding holes in the generator frame.
- > Insert the thread bolts through the bars into the holes in the generator frame.

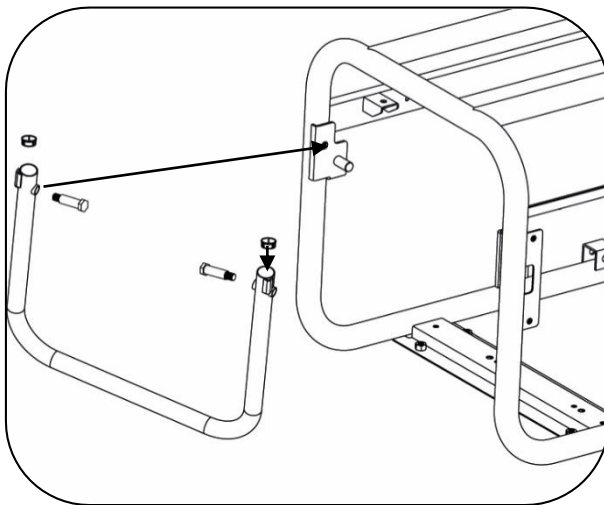

# Pre-Operation Checks

## Oil Level

Check Engine Oil Level Check the engine oil level with the engine stopped and in a level position.

- > Remove the oil filler cap/dipstick and wipe it clean.
- > Insert and remove the dipstick without screwing it into the filler neck. Check the oil level shown on the dipstick.
- > If the oil level is low, fill to the edge of the oil filler hole with the recommended oil .
- > Screw in the oil filler cap/dipstick securely.

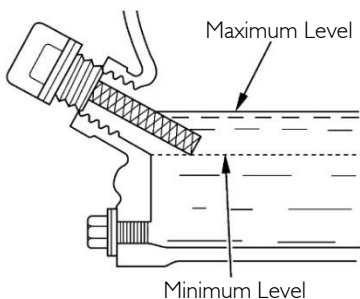
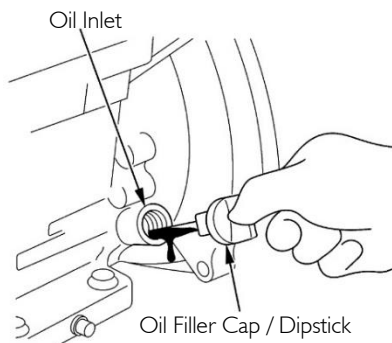

## Air Filter Inspection

A dirty air filter will restrict air flow to the carburettor, reducing engine and output performance.

Remove the **Air Filter Cover** and inspect the filters. Clean or replace dirty filter elements. Always replace damaged filter elements.

Reinstall the air filter and air cleaner cover. Be sure all the parts shown below are in place. Tighten the wing nut securely.

**WARNING! Operating the engine without an air filter, or with a damaged air filter, will allow dirt to enter the engine, causing rapid engine wear. This type of damage is not covered by the Distributor's Limited Warranty.**

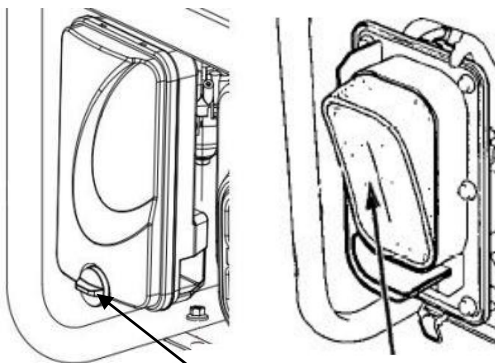

Turn Air Filter Cover Retainer and Remove Air Filter Cover and Element

## Check Fuel Level

With the engine off and on a level surface, remove the fuel tank cap and check the fuel level. You will be able to see the fuel through the fuel strainer. Refill the tank if you cannot see any fuel in the strainer. After refuelling, tighten the fuel tank cap securely.

Always use a funnel or Fuel Bottle with a Flexible spout like shown below

**⚠️ Petrol/Gasoline is highly flammable, volatile and corrosive. You can be burned or seriously injured when handling fuel.**

**⚠️ NEVER fill above the Maximum Fuel Level.**

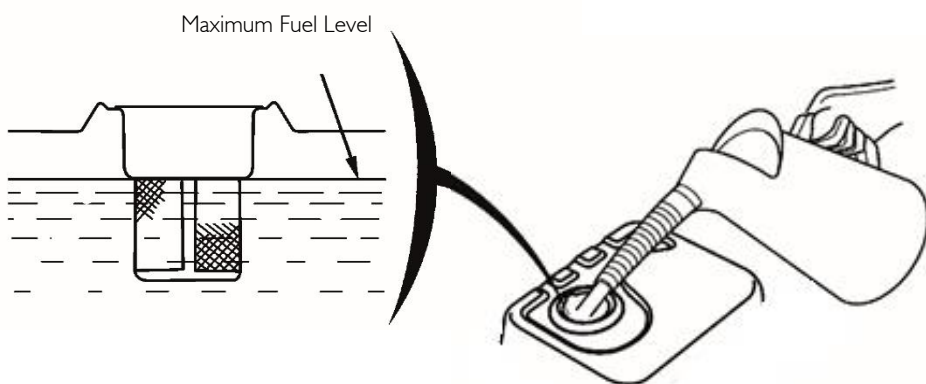

## Recommended Fuel Type

Standard grade E10 and E5 available at fuel stations is suitable for this machine.



# Pre-Operation Checks

## Electrical Unloading

Before operating the machine, always ensure the machine is unloaded. This means, ensure there are no external accessories which are powered by the machine are connected.

## Machine Grounding

**NOTE:** Grounding Cable is not included with the machines.

During any form of operation, grounding the machine is always recommended. This means connecting the machine to a reliable, dedicated ground via a cable/wire from the Ground Terminal on the main panel. Remove the nut from ground point and secure a suitable cable (not included). Re-secure the nut when cable is connected.

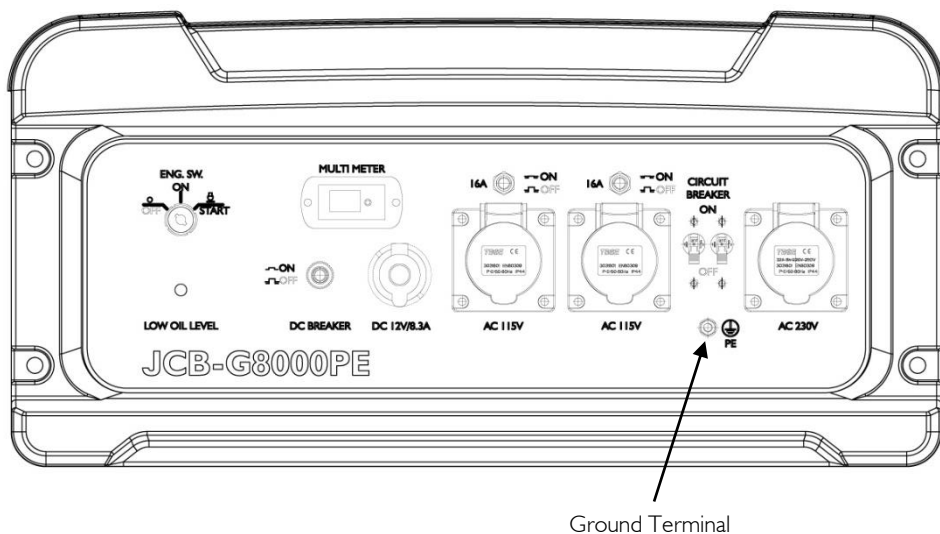

## Battery Connection

**Note\*** This is only applicable to Electric Start Machines

Connect the battery by connecting the Red Wire to the Positive + terminal, and the Black wire to the Negative -.

NEVER allow these 2 wires to touch each other as it can cause damage to the machine and battery.

# Operation

## Starting

Once the machine has been correctly checked following the Pre-Operation checks, the machine can be started.

**WARNING ! – YOU MUST READ AND UNDERSTAND THE WHOLE USER MANUAL BEFORE OPERATING THIS MACHINE**

**WARNING ! – Your Generator must not be operated in wet condition i.e. Raining or poolside. Always operate whilst covered.**

- > Move the fuel valve lever to the ON position
- > To start a cold engine, move the choke lever to the CHOKE position. To restart a warm engine, leave the choke lever in the RUN position.
- > Put the Engine Switch in the “ON” position

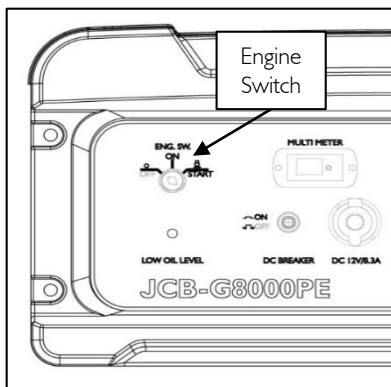
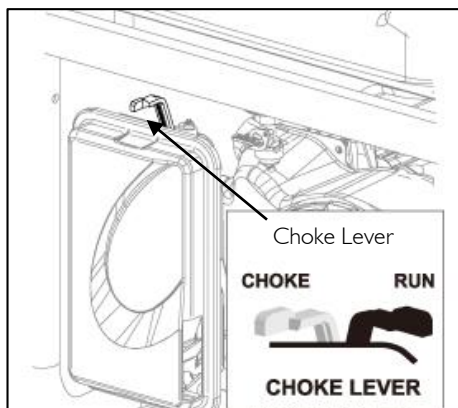
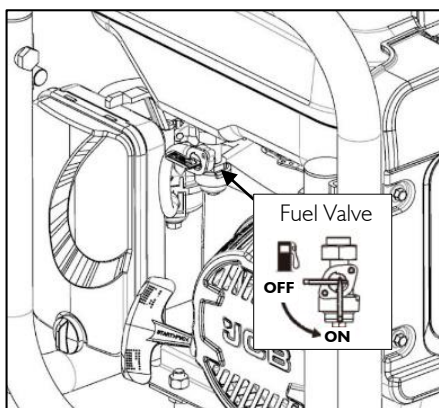

# Operation

## Starting

- > Insert the key into the Power Switch. Put the Power Switch into "ON". Then turn the key into the start position until the machine ignites into life. If the machines doesn't start after 5-10 seconds, stop and try again.
- > Alternatively, you can pull the recoil starter grip lightly until resistance is felt, then pull it briskly. Do not allow the recoil starter grip to snap back against the engine. Return it gently to prevent damage to the starter.
- > If the choke lever was moved to the CHOKE position to start the engine, gradually move it to the RUN position as the engine warms up.
- > The output of the generator is based on Full engine speed. Ensure the choke lever is fully located in the RUN position to ensure full engine speed.

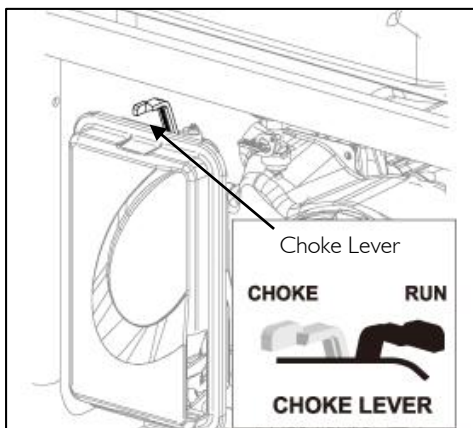
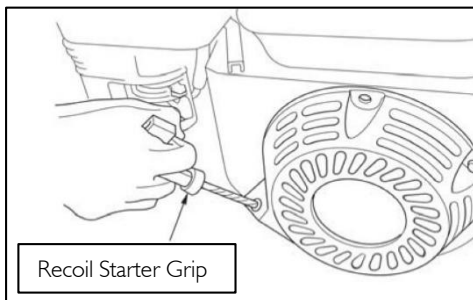

# Operation

## Stopping

**To stop the engine in an emergency, simply turn the ignition switch to the OFF position. Under normal conditions, use the following procedure.**

- > Remove all load from the machine, this means unplugging all connected appliances.
- > Put the Engine Switch into the Off Position
- > Turn the fuel valve to the OFF position.

NOTE\* The machine is very hot after usage. Allow the machine to cool down before moving.

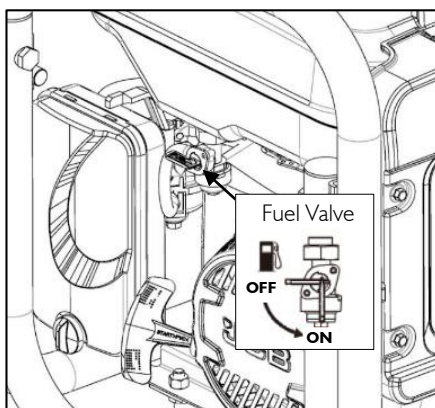
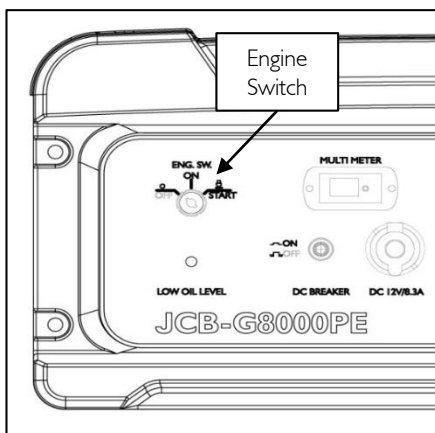

# Operation

## Connecting Appliances

The JCB-G3600P has a rated power of 3200W. This is the maximum amount of power the machine can supply, anything over this will cause the machine to stall, and operate outside of stated specification. This can be dangerous and cause damage to your machine.

- > With the machine running at full speed, connect your appliances one at time.
- > Using either a 115V/230V or DC 12V compatible socket, connect your socket into the desired plug.
- > Ensuring your appliance is off, turn on the circuit breaker for your desired socket. If using either the 115V or 230V outlets, also select your desired voltage.
- > Your appliance should now be supplied with power and safe to use.
- > To disconnect an appliance, turn off the relevant circuit breaker and then disconnect.

NOTE\* If using a suitable socket extension, ensure you follow the same procedure if any additional appliances are connected. Listen to the tune of the engine, if it changes from the previous running speed, disconnect your appliance. Also if your appliance aren't working as intended, this could be an indication the generator can't provide your requested power.

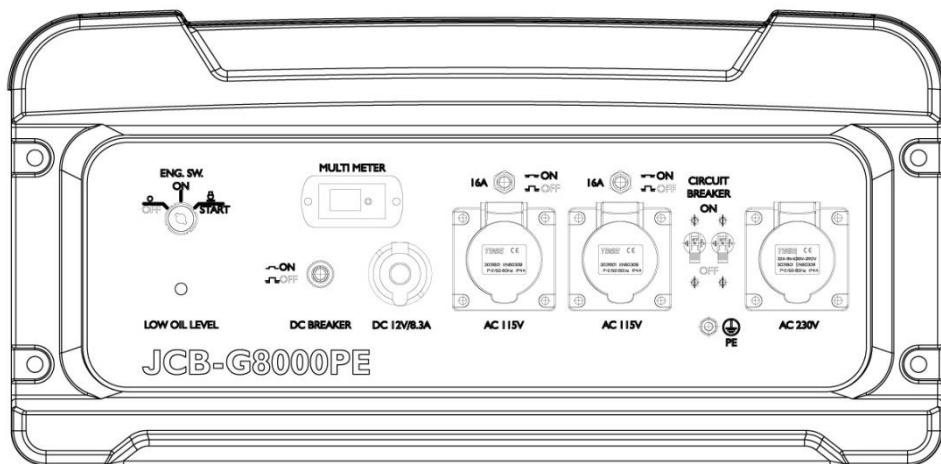

# Operation

## Power Management

The Below table is to provide with a approximate power draw of some general appliances.

NOTE\* These are approximate values, and you should always find out your appliances rated power beforehand.

Electrical Equipment		Rated Power (W)	Starting Power (W)
Household Appliances	27" Television	500	800
	Energy saving lamp	5~50	5~50
	Electric Cooker	1000	1000
	Computer	800	800
	DVD Player	100	100
	Refridgerator	800	1600
	Washing Machine	300	600
	Electric Fan	50	100
	2HP Air Conditioning Unit	1500	3000
Tools	Electric Welder	2500	5000
	Hammer Drill	1000	1500
	Water Pump	800	1200

The Starting Power of some appliances is higher than the Rated Power. Keep this in mind when adding additional appliances to your machine. When starting your appliance, always consider it's Starting Power additionally to any load you're currently requesting

# Maintenance

## Importance of Maintenance

Good maintenance is essential for safe, economical, and trouble-free operation. It will also help reduce air pollution.

Improperly maintaining this machine, or failing to correct a problem before operation, can cause a malfunction in which you can be seriously hurt or killed

Always follow the inspection and maintenance recommendations and schedules in this owner's manual.

To help you properly care for your machine, the following pages include a maintenance schedule, routine inspection procedures, and simple maintenance procedures using basic hand tools. Other service tasks that are more difficult, or require special tools, are best handled by professionals and are normally performed by a technician or other qualified mechanic.

The maintenance schedule applies to normal operating conditions. If you operate your machine under severe conditions, such as sustained high-load or high-temperature operation, or use in unusually wet or dusty conditions, consult your servicing dealer for recommendations applicable to your individual needs and use.

Remember that your servicing dealer knows your machine best and is fully equipped to maintain and repair it.

To ensure the best quality and reliability, use only new, genuine parts or their equivalents for repair and replacement.

Maintenance, replacement, or repair of emission control devices and systems may be performed by any engine repair establishment or individual, using parts that are "certified" to EPA standards.

### MAINTENANCE SAFETY

Some of the most important safety precautions follow. However, we cannot warn you of every conceivable hazard that can arise in performing maintenance. Only you can decide whether or not you should perform a given task.

Failing to properly follow maintenance instructions and precautions can cause you to be seriously hurt or killed.

Always follow the procedures and precautions in the owner's manual.

**Safety Precautions** Make sure the engine is off before you begin any maintenance or repairs. This will eliminate several potential hazards:

Carbon monoxide poisoning from engine exhaust.

Be sure there is adequate ventilation whenever you operate the engine. — Burns from hot parts.

Let the engine and exhaust system cool before touching. — Injury from moving parts.



# Maintenance

## Maintenance Schedule

Schedule for Regular Maintenance		Per Use	Every 20 hours or in the first month of initial use	Every 50 hours or ever 3 months	Every 100 hours or every 6 months	Every 300 hours or every year
Engine Oil	Inspect the Oil Level	•				
	Replace		•		•	
Air Filter	Inspect	•				
	Clean			• (1)		
Fuel Strainer Bowl	Clean				•	
Spark Plug	Clean				•	Replace
Valve Clearnace	Readjust					•
Cylinder Head	Clean	Every 300 Hours (2)				
Fuel Tank and Strainer	Clean	Every 2 Years (2)				

- (1) - Maintenance should be carried out more frequently if used in dusty conditions  
 (2) - Before carrying out maintenance, please seek advice from a qualified technician or the after sales team. For contact details, please see contact us page 32



# Maintenance - Oil Servicing

When changing a machines oil, run the machine for a few minutes. Warm oil will always drain faster and more through compared to oil that's cold.

- > Place a suitable container below the engine to catch the used oil.
- > Remove the oil filler cap/dipstick, oil drain plug and washer.
- > Allow the used oil to drain completely
- > Reinstall the oil drain plug and new washer, and tighten the oil drain plug securely. Please dispose of used motor oil in a manner that is compatible with the environment. We suggest you take used oil in a sealed container to your local recycling centre or service station for reclamation. Do not throw it in the General Waste, pour it on the ground, or down a drain.
- > 3. With the engine in a level position, fill to the upper limit mark (bottom edge of the oil fill hole) on the dipstick with the recommended oil.

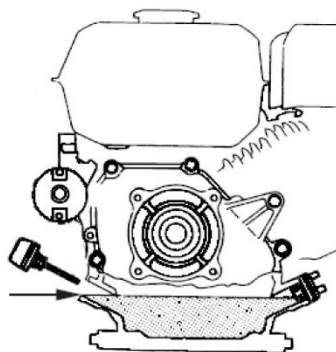
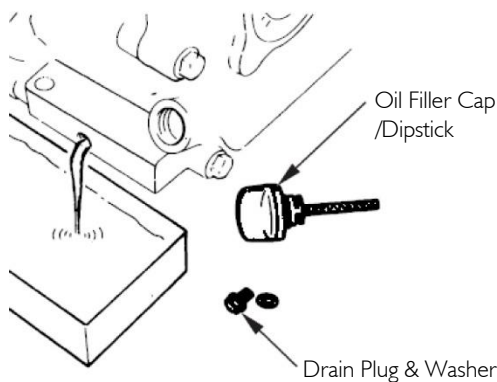

## Oil Grade

Use 4-stroke motor oil that meets or exceeds the requirements for API service classification SJ, SL, or equivalent. Always check the API service label on the oil container to be sure it includes the letters SJ, SL, or equivalent. SAE 15W-40 is recommended for general use.

Other viscosities shown in the chart may be used when the average temperature in your area is within the indicated range.

Recommended Engine Oil Type								
				10W-30				
			5W-30				10W-40	
			5W-30 Synthetic					
°F	-20	0	20	40	60	80	100	120
°C	-28.9	-17.8	-6.7	4.4	15.6	26.7	37.8	48.9
Ambient temperature								

# Maintenance - Spark Plug



## Recommended Spark Plugs – NGK:BPR7ES/Champion:RN7YC

This variation of spark plug is recommended for normal engine running conditions and temperatures. Incorrect specifications of sparkplug can cause damage to your machine. Ensure any sparkplug is correctly gapped and free of any deposits

- > Firstly remove the Spark plug cap. This is a push/pull fit.
- > Using a suitable spark plug wrench, loosen the spark plug and remove it.
- > Inspect the sparkplug. Replace if your inspection finds:
  1. Visible Damage
  2. Badly fouled with Oil/Carbon
  3. Washer health is compromised
- > Using a feeler gauge, check the gap of the spark electrode. The gap should be with these tolerances 0.7-0.8 mm (0.026-0.031 inch).
- > Reinstall the sparkplug, firstly winding it by hand, this is to avoid cross threading.
- > After properly seated, fully tighten using spark plug wrench.
- > When the washer has started to compress tighten to the following instruction:
  1. New Sparkplug – a 1/2 Turn tight
  2. Re-used Spark Plug – a 1/8 to 1/4 Turn tight

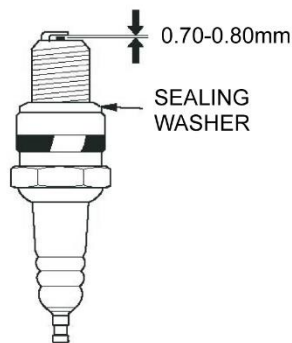
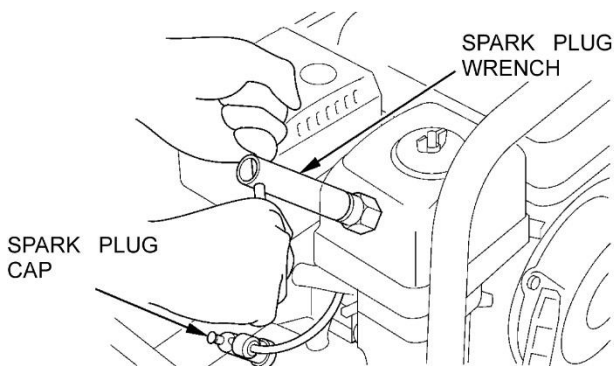

## Maintenance – Sediment Filter

- > Close the fuel valve and remove the sediment bowl.
- > Take out the O-type seal ring and strainer.
- > Clean the sediment bowl, O-type seal ring and strainer with incombustible or high-flash solvent.
- > Reinstall the O-type seal ring and strainer, and tighten the sediment bowl.
- > Open the fuel valve and inspect for leakage.

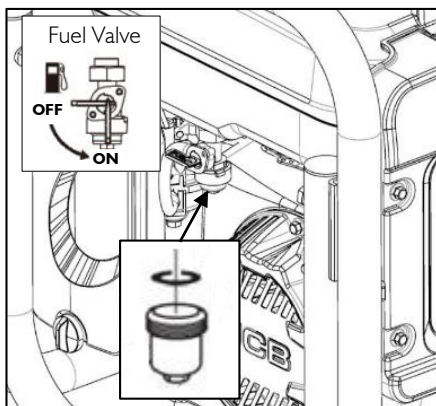

## Cleaning Air Filter

For Illustration refer to Page 13 "Air filter Inspection"

- > Open the cover with the lock nut and remove the foam air filter element.
- > Wash the foam element in liquid detergent and water, then rinse in clean water and squeeze dry in a clean cloth.
- > Saturate the foam filter with clean engine oil, remove excess by squeezing into a dry clean cloth.
- > Refit the air filter and air filter cover.

# Troubleshooting

Fault	Cause	Action
The Machine doesn't Start	No fuel	Fill the oil tank with gasoline
	The Fuel valve is not turned on	Turn the fuel valve to ON
	The Fuel valve is blocked	Clean the fuel bowl (refer to page 27)
	No engine oil or the engine oil level is low	Add oil
	The engine switch is turned off	Turn the switch to the "on" position
	The spark plug fails	Clean or replace the spark plug (refer to page 26)
There is no power output	The circuit breaker is in the off position	Turn the circuit breaker to the "on" position
	The plug is poorly contacted	Remove and refit the plug.
The unit shudders during operation	The choke lever position is incorrect	Move the choke lever to the "open" position during operation
The unit emits white smoke	The temperature of the engine is too high, maybe overloaded	Let the engine run without load for more than 10 minutes
	The fuel is contaminated	Use fresh clean fuel
The unit emits black smoke	The air filter is dirty	Clean the filter element of the air filter
	The load is too heavy	Reduce load to the rated limit
The unit emits blue smoke	The engine oil is overfilled	Drain oil to correct level
	The engine oil type is incorrect	Choose appropriate engine oil model
The Power Decreases over time	The spark plug fails	Clean or Replace Spark Plug
	The valve clearance are out of adjustment	Adjust the Valve Clearances

# Wiring Diagram

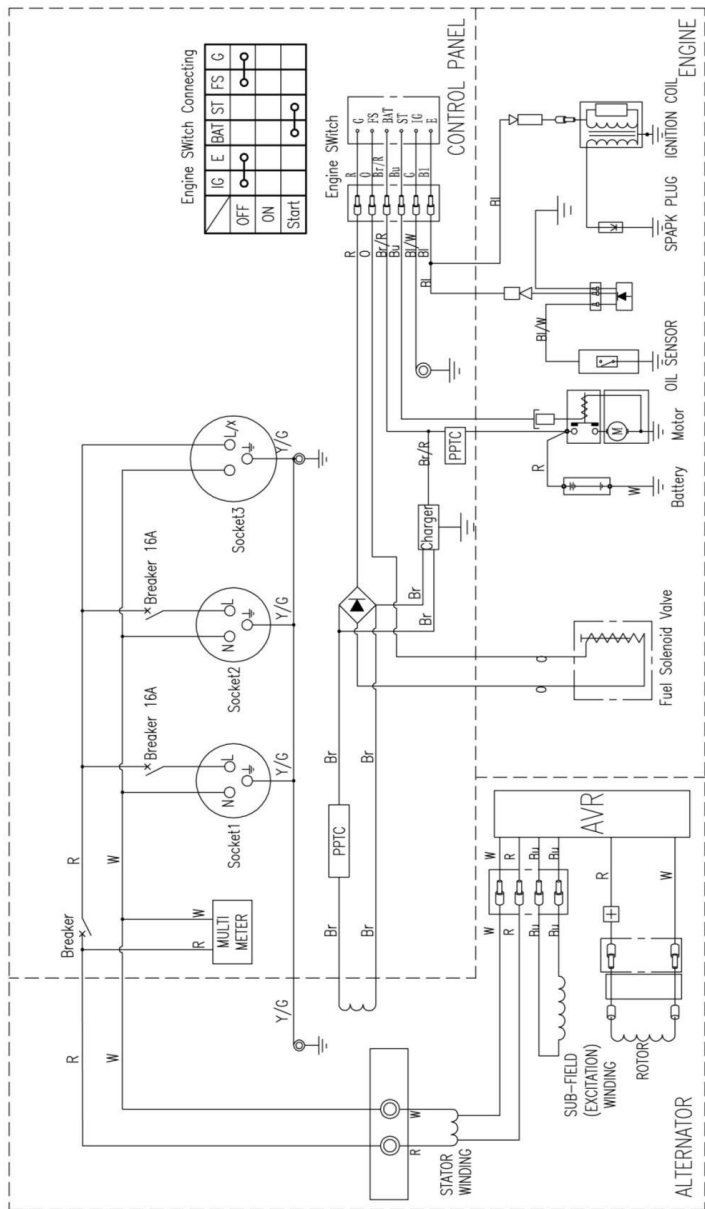

Engine Switch Connecting

OFF	IG	E	BAT	ST	FS	G
ON						
Start						

Engine Switch

R	O	G
Br/R	Br/N	FS
Bu	Bu	BAT
Bu/W	C	ST
Br	Bl	IG

Bl	Black	Br	Brown	Y/G	Yellow/Green
O	Orange	Br/R	Brown/Red	B/W	Black/White
Bu	Blue	LB	Light Blue	G	Green
Gr	Gray	Bl	Black		
R	Red	W	White		

WIRING DIAGRAM OF 220V/230V/240V GENERATOR SET

# Specifications

Model	JCB-G8000PE
Running Watts/Kw	7500/7.5
Max. Watts / kw	7900/7.9
Rated Voltage (v)	115/230
Rated Frequency(Hz)	50
Displacement (cc)	457
Start method	Recoil/E-Start
Oil capacity (mm)	1100
Air Cleaner Type	Metal
Low Oil Sensor / Alarm	Yes
Ignition System	T.C.I
Alternator Type	Brushed
Phase	Single
Socket Configuration	1x230v 32A Blue + 2x 115v 16A Yellow Sockets
Fuel Tank Size (L)	25
Frame Diameter (mm)	32
Diimensions (mm)(LxWxH)	690x675x655
Sound Pressure Level LpA (dB)	75.57
Sound Power Level LWA (dB)	95.8
Guaranteed Sound Power Level (dB)	97

# Tightening Settings and Tolerances

Inlet Valve Clearance (mm)	0.08~0.12
Exhaust Valve Clearance (mm)	0.13~0.17
Big End Bolts(Nm)	11~13
Valve Rocker Lock Nuts (Nm)	8~12
Rocker Cover Plate (Nm)	8~12
Crankcase Bolts (Nm)	26~30
Carburettor Nuts (Nm)	9~11
Governor arm Clamp bolt (Nm)	9~12
Exhaust Manifold (Nm)	5~10
Head Bolts (Nm)	26~30
Flywheel Retention Nut (Nm)	70~80
Sump Plug (Nm)	15~25
Rotor Drawbolt (Nm)	8~12
Stator Retaining Bolts (Nm)	25~30



## Warranty

Proof of purchase will be required before you make a warranty claim. Full warranty terms and conditions can be found on the support website:

[www.jcb-tools.co.uk](http://www.jcb-tools.co.uk)

## Manual Updates

Our manuals are constantly being reviewed and updated. Should you find an error, omission or something unclear, please contact us for assistance. We reserve the right to make any modifications without prior notice whenever necessary.

Our latest manuals are also placed online. All our manuals can be downloaded at: [www.jcb-tools.co.uk](http://www.jcb-tools.co.uk)

## Returning Your Product

If you are returning your product, please contact the dealer for their returns policy.

## Leaving a Review

We work very hard to give all of our customers the best possible service. If you have any problems, before leaving negative feedback, please contact us to give us a chance to resolve the issue. We would be delighted if you left us positive feedback! To leave a review, please go to: [uk.trustpilot.com](http://uk.trustpilot.com)

## Ordering Spare Parts

You can find the spare part you are looking for at [power-spareparts.co.uk](http://power-spareparts.co.uk)

# Contact Us

## Need Help? Talk To Our Experts

Our friendly aftersales team will be more than happy to help you.



### Phone

Call our team on 01646 687 880



### Email

[aftersales@genpower.co.uk](mailto:aftersales@genpower.co.uk)



### Post

Genpower Ltd, Isaac Way, Pembroke Dock, Pembrokeshire, SA72 4RW.



### Support Website

Go to Go to [www.jcb-tools.co.uk](http://www.jcb-tools.co.uk)





## Recycling and Disposal

We do not offer a takeback scheme for the recovery of Waste Electrical Electronic Equipment (WEEE) & Batteries. Instead the responsibility to dispose of WEEE and/or Batteries is passed onto you by us. So when it becomes necessary to dispose of your machine you must take it to your local Civic Amenity Site. For further information please contact your local Authority for disposal advice.

You **MUST** make sure that all unused oil and fuel is disposed of correctly either beforehand or at your local Civic Amenity Site.

- > Under **NO** circumstances must any fuel or oil be put down any drains.
- > Certain products contain WEEE waste which should not be disposed of in your domestic waste.
- > You **MUST** recycle WEEE in accordance with your local authority or recycling centre.
- > Certain products contain batteries which should not be disposed of in your domestic waste.
- > You **MUST** recycle batteries in accordance with your local authority or recycling centre.
- > Unwanted packaging and materials should be stored and taken to a recycling centre so it can be disposed of in a manner which is compatible with the environment.

We are a Member of the VALPAK National Compliance Scheme and our registration number is RM08660. For further information about disposal please contact your Local Authority.

You can also get more advice and guidance about recycling at the following website <http://www.recycle-more.co.uk>

Should you pass this product on to another user either sold or loaned, you **MUST** pass on this user manual. This will make sure that all other users can use and maintain this machine safely.

## Environmental Protection

- > Environmental protection should be a priority of considerable importance when using the machine, for the benefit of both social coexistence and the environment in which we live. Try not to cause any disturbance to the surrounding area.
- > You must comply with local regulations and provisions for the disposal of packaging, oils, fuel, filters, damaged parts or any elements which have a strong impact on the environment. This waste must not be disposed of as normal waste. It needs to be separated and taken to specified waste disposal centres where the material will be recycled.
- > You must comply with local regulations for the disposal of waste materials after mowing.
- > When disposing, do not pollute the environment with the machine, but hand it over to a disposal centre, in accordance with the local laws in force.

# CE DECLARATION OF CONFORMITY

**We,**  
JCB Tools

**Declare that the product:**

*Description*  
7500W Generator  
*Type*  
JCB-G8000PE  
*Function*  
Producing Power

**Complies to the Following Directives;**

Machinery Directive  
**2006/42/EU**

Low Voltage Directive  
**2014/35/EU**

EMC Directive  
**2014/30/EU**

Noise Emission Directive  
**2000/14/EC**

**The person authorized to compile this technical file:**

Date: 01/12/2022

Signature

Name/title: Roland.J.Llewellyn / Managing Director  
JCB Tools are a Licensee of J.C.Bamford Excavators Ltd, operated via Genpower Ltd.  
Address: JCB Tools, Isaac Way, Pembroke Dock, SA72 4RW

# UKCA DECLARATION OF CONFORMITY

**We,**  
JCB Tools

**Declare that the product:**

*Description*  
7500W Generator  
*Type*  
JCB-G8000PE  
*Function*  
Producing Power

**Complies to the Following Directives;**

Machinery Directive - **2008 (S.I. 2008/1597)**  
Low Voltage Directive - **2014/35/EU**  
EMC Directive - **2014/30/EU**  
Noise Emission Directive - **2000/14/EC**  
Electromagnetic Compatibility Regulations 2016 (SI 2016 No. 1091)  
EURO V : (EU) 2016/1628  
2011/65/EU+(EU)2015/863  
REACH SVHC 224

The following harmonised standards and technical specifications have been applied:

**BS EN ISO 8528-13:2016,**  
**EN 60204-1:2018,**  
**EN ISO 12100:2010**  
**EN 55012:2007+A1:2009**  
**EN IEC 61000-6-1:2019**

**The person authorized to compile this technical file:**

Date: 01/12/2022

Signature



Name/title: Roland.J.Llewellyn / Managing Director

JCB Tools are a Licensee of J.C.Bamford Excavators Ltd, operated via Genpower Ltd.

Address: JCB Tools, Isaac Way, Pembroke Dock, SA72 4RW